

Self-Enclosed Nexus[®]

1500+ Meter in Assembly



NEMA 1
Indoor Rated

- Ideal for Retrofit Meter Solutions
- Extends Switchgear Capability
- Pre-Wired and Configured
- Eliminates Wiring and Installation Errors

User Manual

V.1.10

April 5, 2023



This page intentionally left blank.

Nexus® 1500+ Meter in Enclosure User Manual Version 1.10

Published by:

Electro Industries/GaugeTech (EIG)

1800 Shames Drive

Westbury, NY 11590

Copyright Notice

All rights reserved. No part of this publication may be reproduced or transmitted in any form or by any means, electronic or mechanical, including photocopying, recording, or information storage or retrieval systems or any future forms of duplication, for any purpose other than the purchaser's use, without the expressed written permission of Electro Industries/GaugeTech.

© 2023 Electro Industries/GaugeTech

Nexus®, CommunicatorPQA®, MeterManagerPQA®, EnergyPQA.com®, and EnergyPQA® are registered trademarks of Electro Industries/GaugeTech. The distinctive shape, style, and overall appearance of the Nexus® 1500+ meter is a trademark of Electro Industries/GaugeTech. HMIPQA™, HMIPQA+™, EnergyReporterPQA™, V-Switch™, and Constant Calibration™ are trademarks of Electro Industries/GaugeTech.

Customer Service and Support

Customer support is available 8:00 am to 8:00 pm, Eastern Standard Time, Monday through Friday. Please have the model, serial number and a detailed problem description available. If the problem concerns a particular reading, please have all meter readings available. When returning any merchandise to EIG, a return materials authorization number is required. For customer or technical assistance, repair or calibration, phone 516-334-0870 or fax 516-338-4741.

Product Limited Warranty Certificate

1. Electro Industries/Gauge Tech ("Electro") warrants its metering products ("the Product") against defects in material and workmanship, subject to the terms and conditions stated herein. This limited warranty extends to and covers only the Customer, as the purchaser of Electro's Product; the Customer represents and warrants to Electro that the Customer is subject to and bound by the limited warranty and disclaimer of warranty contained herein.

2. PRODUCT LIMITED WARRANTY

Electro warrants that commencing from the Product's date of delivery (the date the Product leaves Electro's manufacturing facility) and continuing immediately following thereafter for a period of four (4) consecutive years, that the Product will be free from defects in material and workmanship, and except for the foregoing, the Product is sold AS IS with all faults. This warranty does not apply to defects resulting from unauthorized modification, misuse, or use of the Product for any use other than electrical power monitoring, which is the intended and normal use of the Product. The Customer's sole and exclusive remedy and the entire liability of Electro under this limited warranty will be, at Electro's option, as follows: (i) the Product's repair; or (ii) shipment of a replacement Product within the above stated warranty period. To exercise this limited warranty, the Customer must give notice (See Section 5) to Electro's customer-support department and give additional notice to Electro's customer-support department by facsimile or by telephone for Electro's instructions for the Product's return or repair. If the Product is repaired, Electro will ship the repaired Product to the Customer. THE FOREGOING WARRANTIES ARE THE SOLE WARRANTIES, EXPRESS OR IMPLIED, GIVEN BY ELECTRO IN CONNECTION WITH THE PRODUCT, AND ELECTRO DISCLAIMS ALL OTHER WARRANTIES, INCLUDING BUT NOT LIMITED TO WARRANTIES OF MERCHANTABILITY, FITNESS FOR A PARTICULAR PURPOSE, NON-INFRINGEMENT OF THIRD-PARTY RIGHTS AND WARRANTIES AGAINST LATENT DEFECTS. The Cus-

tomers must notify Electro promptly, but in no event more than four (4) years after the Product's date of delivery of any claimed breach of this warranty, or such claim shall be time barred.

3. PRODUCT LIMITED WARRANTY RESTRICTIONS

THE LIMITED WARRANTY CONTAINED HEREIN WILL NOT BE GIVEN OR APPLY, AND NO EXPRESS OR IMPLIED WARRANTY, INCLUDING BUT NOT LIMITED TO WARRANTIES OF MERCHANTABILITY, FITNESS FOR A PARTICULAR PURPOSE, NON-INFRINGEMENT OF THIRD PARTY RIGHTS AND WARRANTIES AGAINST LATENT DEFECTS SHALL BE DEEMED APPLICABLE, GIVEN OR PROVIDED BY ELECTRO WITH RESPECT TO OR CONCERNING THE PRODUCT, IF: (a) the Product has been altered, except by Electro or Electro's authorized representative; (b) the Product has not been installed, operated, repaired, or maintained in accordance with instructions supplied by Electro; (c) the Product has been subjected to abnormal physical or electrical stress, abnormal environmental conditions, misuse, negligence, or accident; (d) the Product is used in ultrahazardous activities; or (e) the Customer failed to pay Electro the Product's purchase price pursuant to the Terms of Sale published by Electro at <https://www.electroind.com/pdf/docs/electro-terms-of-sale.pdf>.

4. DISCLAIMER OF WARRANTY AND LIMITATIONS OF LIABILITY

EXCEPT AS EXPRESSLY GIVEN IN THIS LIMITED WARRANTY SECTION, ALL EXPRESS OR IMPLIED CONDITIONS, REPRESENTATIONS, AND WARRANTIES INCLUDING, WITHOUT LIMITATION, ANY IMPLIED WARRANTY OR CONDITION OF MERCHANTABILITY, FITNESS FOR A PARTICULAR PURPOSE, NON-INFRINGEMENT, SATISFACTORY QUALITY, NON-INTERFERENCE, ACCURACY OF INFORMATIONAL CONTENT, OR ARISING FROM A COURSE OF DEALING, LAW, USAGE, OR TRADE PRACTICE, ARE HEREBY EXCLUDED IN THEIR ENTIRETY TO THE FULL EXTENT ALLOWED BY APPLICABLE LAW AND ARE EXPRESSLY DISCLAIMED BY ELECTRO, AND ARE WAIVED BY THE CUSTOMER. TO THE EXTENT AN IMPLIED WARRANTY CANNOT BE EXCLUDED, SUCH WARRANTY IS LIMITED IN DURATION TO THE EXPRESS WARRANTY PERIOD STATED HEREIN. THIS DISCLAIMER AND EXCLUSION SHALL APPLY EVEN IF THE EXPRESS LIMITED WARRANTY SET FORTH ABOVE FAILS OF ITS ESSENTIAL PURPOSE.

EXCEPT AS EXPRESSLY PROVIDED IN THIS SECTION, ELECTRO HEREBY DISCLAIMS AND CUSTOMER WAIVES ALL REPRESENTATIONS, CONDITIONS AND WARRANTIES (WHETHER EXPRESS, IMPLIED, OR STATUTORY), INCLUDING, WITHOUT LIMITATION,

ANY WARRANTY OR CONDITION (A) OF MERCHANTABILITY, FITNESS FOR A PARTICULAR PURPOSE, NONINFRINGEMENT, TITLE, SATISFACTORY QUALITY, QUIET ENJOYMENT, ACCURACY, OR SYSTEM INTEGRATION, OR (B) ARISING FROM ANY COURSE OF DEALING, COURSE OF PERFORMANCE, OR USAGE IN THE INDUSTRY. TO THE EXTENT AN IMPLIED WARRANTY OR CONDITION CANNOT BE DISCLAIMED, SUCH WARRANTY OR CONDITION IS LIMITED IN DURATION TO THE APPLICABLE EXPRESS WARRANTY PERIOD. CUSTOMER SHALL NOT IN ANY EVENT BE ENTITLED TO, AND ELECTRO SHALL NOT BE LIABLE FOR, INDIRECT, SPECIAL, INCIDENTAL, PUNITATIVE OR CONSEQUENTIAL DAMAGES OF ANY NATURE INCLUDING, BUT NOT LIMITED TO AND WITHOUT LIMITATION, BUSINESS INTERRUPTION COSTS, REMOVAL OR REINSTALLATION COSTS, REPROCUREMENT COSTS, LOSS OF PROFIT OR REVENUE, LOSS OF DATA, PROMOTIONAL OR MANUFACTURING EXPENSES, OVERHEAD, INJURY TO REPUTATION OR LOSS, EVEN IF ELECTRO HAS BEEN ADVISED OF THE POSSIBILITY OF SUCH DAMAGES.

ELECTRO'S LIABILITY TO THE CUSTOMER, AND CUSTOMER'S RECOVERY FROM ELECTRO FOR ANY CLAIM, INCLUDING BUT NOT LIMITED TO A WARRANTY CLAIM, SHALL NOT EXCEED CUSTOMER'S PURCHASE PRICE FOR THE PRODUCT PAID BY THE CUSTOMER FOR THE PRODUCT, WHICH GAVE RISE TO SUCH CLAIM IRRESPECTIVE OF THE NATURE OF THE CLAIM, WHETHER IN CONTRACT, TORT, WARRANTY OR OTHERWISE. ELECTRO SHALL NOT BE LIABLE FOR, AND THE CUSTOMER SHALL INDEMNIFY, DEFEND AND HOLD ELECTRO HARMLESS FROM THE FOLLOWING: ANY CLAIMS BASED ON ELECTRO'S COMPLIANCE WITH END USER'S OR CUSTOMER'S DESIGNS, SPECIFICATIONS OR INSTRUCTIONS; MODIFICATION OF ANY PRODUCT BY A PARTY OTHER THAN ELECTRO; MODIFICATION OF ANY SOFTWARE MADE BY A PARTY OTHER THAN ELECTRO; THE USE OF THE PRODUCT OR SOFTWARE FOR ANY USE OTHER THAN ELECTRICAL POWER MONITORING; AUTHORIZED OR UNAUTHORIZED USE OF THE PRODUCT OR SOFTWARE; MISUSE OF THE PRODUCT OR SOFTWARE; THE SOFTWARE'S OR PRODUCT'S USE IN COMBINATION WITH OTHER EQUIPMENT, GOODS, SOFTWARE OR PRODUCT. IF, FOR ANY REASON, THE FOREGOING LIMITATIONS ARE FOUND BY AN ARBITRATION PANEL OR COURT OF COMPETENT JURISDICTION TO BE INVALID OR INAPPLICABLE UNDER ANY APPLICABLE LAW, CUSTOMER AGREES THAT ELECTRO'S TOTAL LIABILITY FOR ALL DAMAGES, LOSSES, OR CAUSES OF ACTION OF ANY KIND OR NATURE SHALL BE LIMITED TO CUSTOMER'S PURCHASE PRICE FOR THE PRODUCT LICENSED BY THE CUSTOMER FROM ELECTRO, WHICH GAVE RISE TO SUCH CLAIM, WITHOUT REGARD TO ANY ACTUAL DAMAGES; INDIRECT, SPECIAL,

DIRECT OR CONSEQUENTIAL DAMAGES; PUNITIVE OR EXEMPLARY DAMAGES PROVIDED FOR BY ANY SUCH APPLICABLE LAW.

5. NOTICES

All notices required or permitted under this limited warranty will be in writing and will be deemed given one (1) day after deposit with a commercial express courier specifying next day delivery (or two (2) days for international courier packages specifying 2-day delivery), with written verification of receipt. All communications will be sent to the address set forth below, and notices to Electro shall be further addressed to Attn: Customer Support.

Electro Industries/Gauge Tech
1800 Shames Drive
Westbury, NY 11590
Attn: Customer Support

Use of Product for Protection

Our products are not to be used for primary over-current protection. Any protection feature in our products is to be used for alarm or secondary protection only.

Statement of Calibration

Our instruments are inspected and tested in accordance with specifications published by Electro Industries/GaugeTech. The accuracy and a calibration of our instruments are traceable to the National Institute of Standards and Technology through equipment that is calibrated at planned intervals by comparison to certified standards. For optimal performance, EIG recommends that any meter, including those manufactured by EIG, be verified for accuracy every five years using NIST traceable accuracy standards. In general, EIG metering devices should not require regular adjustments to maintain published accuracy. If the meter is to be used for revenue purposes, follow the verification and calibration guidelines adopted by your local utility.

Disclaimer

The information presented in this publication has been carefully checked for reliability; however, no responsibility is assumed for inaccuracies. The information contained in this document is subject to change without notice.

Symbols Used in This Manual



This warning symbol indicates that the operator must refer to an important explanation in the operating instructions. The word following the symbol indicates the type of warning being given.

Ce symbole d'avertissement indique que l'opérateur doit se référer à une explication importante dans les instructions d'utilisation. Le mot suivant le symbole indique le type d'avertissement ne soit donné.

CAUTION!

The instructions given must be followed to prevent damage to equipment.

Les instructions doivent être respectées pour éviter d'endommager l'équipement.

WARNING!

The instructions given must be followed to prevent serious injury to people.

Les instructions doivent être respectées pour d'éviter de graves blessures aux personnes.

Our Focus at Electro Industries/GaugeTech (EIG)

EIG exclusively delivers integrated energy and power quality monitoring solutions utilizing AI and deep industry expertise to improve reliability, efficiency, and sustainability. With over 50 years' experience in the electrical industry, EIG has developed extensive energy management and power quality expertise to help customers find ideal solutions to complex challenges. Our corporate culture promotes being cutting edge and investing in R&D to continually improve our customer experience.

Our solutions are designed to deliver results in days, not years. Known for our reputation as being a dependable provider and for exemplary service and support, EIG is committed to customer satisfaction.

Table of Contents

Copyright Notice i

Customer Service and Support ii

Product Limited Warranty Certificate ii

Use of Product for Protection v

Statement of Calibration v

Disclaimer v

Symbols Used in This Manual vi

Our Focus at Electro Industries/GaugeTech (EIG) vi

1.1: Product Handling 1-1

1: Introduction 1-1

1.2: Safety Precautions 1-2

1.3: Storage 1-3

1.4: Enclosure Compliance 1-3

2: Installation 2-1

2.1: Recommended Procedures for Wire Entry Hole Cutting 2-6

2.2: Enclosure Installation 2-8

2.2.1: Installation Steps 2-10

2.2.2: Door Locking Instructions 2-12

3. Electrical Wiring 3-1

3.1: Wiring Instructions 3-2

3.1.1: Wiring Diagrams 3-3

4: Operation 4-1

4.1: Overview 4-1

4.2: Troubleshooting 4-1

5. Maintenance 5-1

5.1: Removing a Meter From Service 5-1

5.2: Reinstalling the Meter 5-4

6. Ordering Information 6-1

1: Introduction

The Nexus®1500+ Meter in Enclosure lets you expand your switchgear capability and/or easily meter circuits without expensive and time-consuming redesign. Simply mount the enclosure in any convenient location, next to your switchgear or on a wall, and you are ready to go, with no downtime.

This is an ideal solution for a retrofit when there is no metering compartment available. The unit comes standard with a NEMA 1* rated enclosure and is factory wired with the meter installed. Standard safety equipment includes voltage fuses and shorting blocks for current transformers. See Chapter 6 for ordering instructions.

1.1: Product Handling



CAUTION! READ AND UNDERSTAND THE INSTRUCTIONS CONTAINED IN THIS DOCUMENT BEFORE ATTEMPTING TO UNPACK, INSTALL, OPERATE, OR MAINTAIN THIS EQUIPMENT.

Every effort is made to insure that the equipment arrives undamaged and ready to be installed. Packing is designed to protect internal components as well as the enclosure. Do not remove protective packing until you are ready to install the equipment.

When you receive the equipment, you should inspect the shipping container for any obvious signs of rough handling and/or external damage that occurred during transportation. Record any external and internal damage for reporting to the transportation carrier and EIG. All claims should be as specific as possible and include general order numbers.

You will find this manual in a plastic bag in the shipping container. Store this document in a safe place.

* NEMA 1 Enclosures are constructed for indoor use to provide a degree of protection to personnel against access to hazardous parts and to provide a degree of protection of the equipment inside the enclosure against ingress of solid foreign objects (falling dirt). (Taken from *NEMA Enclosure Types* from the National Electrical Manufacturers Association.)

1.2: Safety Precautions



WARNING! All safety codes, safety standards, and/or regulations must be strictly observed in the installation, operation, and maintenance of this device.

Hazardous voltages that can cause death or severe personal injury are present inside enclosure. Follow proper installation, operation, and maintenance procedures to avoid these voltages.

Avertissement! tous les codes de sécurité, normes de sécurité et règlements doivent être suivis strictement dans l'installation, le fonctionnement et la maintenance de cet appareil.

Des tensions dangereuses peuvent provoquer la mort ou des blessures graves. suivre l'installation adéquate, le fonctionnement et les procédures de maintenance pour éviter ces tensions.

Completely read and understand the material presented in this document before attempting installation, operation, or application of the equipment. In addition, only qualified persons should be permitted to perform any work associated with the equipment. Any wiring instructions presented in this document must be followed precisely. Failure to do so could cause permanent equipment damage.

All possible contingencies that may arise during installation, operation, or maintenance, and all details and variations of this equipment do not purport to be covered by these instructions. If further information is desired by purchaser regarding a particular installation, operation, or maintenance of particular equipment, contact an EIG representative.

1.3: Storage

Although it has been well packaged, this equipment should not be stored outdoors. If the equipment is to be stored indoors for any period of time, it should be stored with its protective packaging in place. Refer to the *Nexus® 1500+ Meter User Manual* for the meter's storage requirements. You can download the manual from EIG's website: <https://www.electroind.com/products/nexus-1500-power-quality-meter-in-enclosure/>

The temperature rating for indoor enclosure storage is (-20 to +60) °C/(-4 to +140) °F.

1.4: Enclosure Compliance

UL / cUL Listed, UL508A, File number: E358101.

This page intentionally left blank.

2: Installation



WARNING! All safety codes, safety standards, and/or regulations shall be strictly observed in the installation, operation, and maintenance of this device. **This device shall be installed in an un-energized condition and as per the National Electric Code.**

AVERTISSEMENT! Tous les codes de sécurité, normes de sécurité et règlement doivent être suivis strictement pour l'installation, le fonctionnement et la maintenance de cet appareil. **Cet appareil doit être installé hors tension conformément au code électrique national (National Electric Code).**

Choose a mounting location that offers a flat, rigid mounting surface capable of supporting the weight of the equipment. The unit weighs 38 lbs (17.24 kilograms) maximum. Mount the equipment in a suitable environment. This enclosure is designed for NEMA 1 rated environments and is manufactured of painted steel.

Check to make certain that there are no pipes, wires, or other mounting hazards in the immediate mounting area that could create a problem. Verify that there will be enough clearance around the enclosure to run wiring, and that the door can be opened completely, allowing access to all internal wiring. EIG recommends at least 2 feet of clearance around the enclosure. See Section 2.1 for enclosure dimensions.

Carefully remove all packing material from the unit. Even though an equipment inspection was made when the equipment was received, make another careful inspection of the enclosure and the devices inside as packing material is removed. Be especially alert for distorted metal, loose wires, or damaged components. This is important because wiring can come loose in shipping and could cause a short circuit or voltage to be on the wrong terminal.



WARNING! Extreme care shall be taken when mounting the enclosure, and making wire entry holes, to prevent metal chips, filings, and other contaminants from entering the enclosure which may damage the equipment and create a hazardous condition.

AVERTISSEMENT! Attention extrême lors de la monture de l'enceinte et lors de la mise à terre pour prévenir les articles métalliques, remplissage et autre contaminant de l'entrée de l'enceinte qui peuvent provoquer une condition dangereuse de l'équipement.

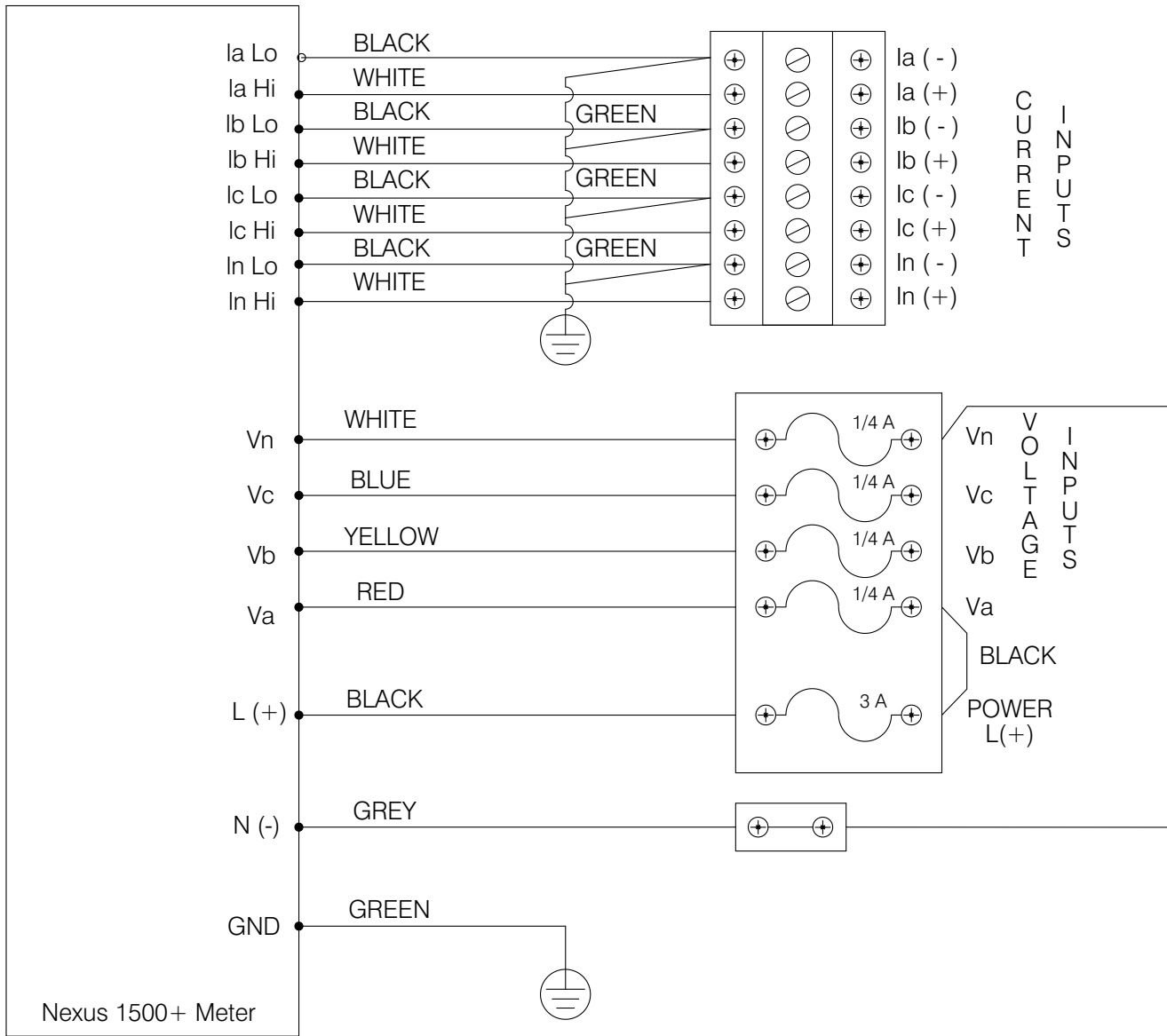

Figure 2.1: 120 Configuration Internal Wiring Schematic

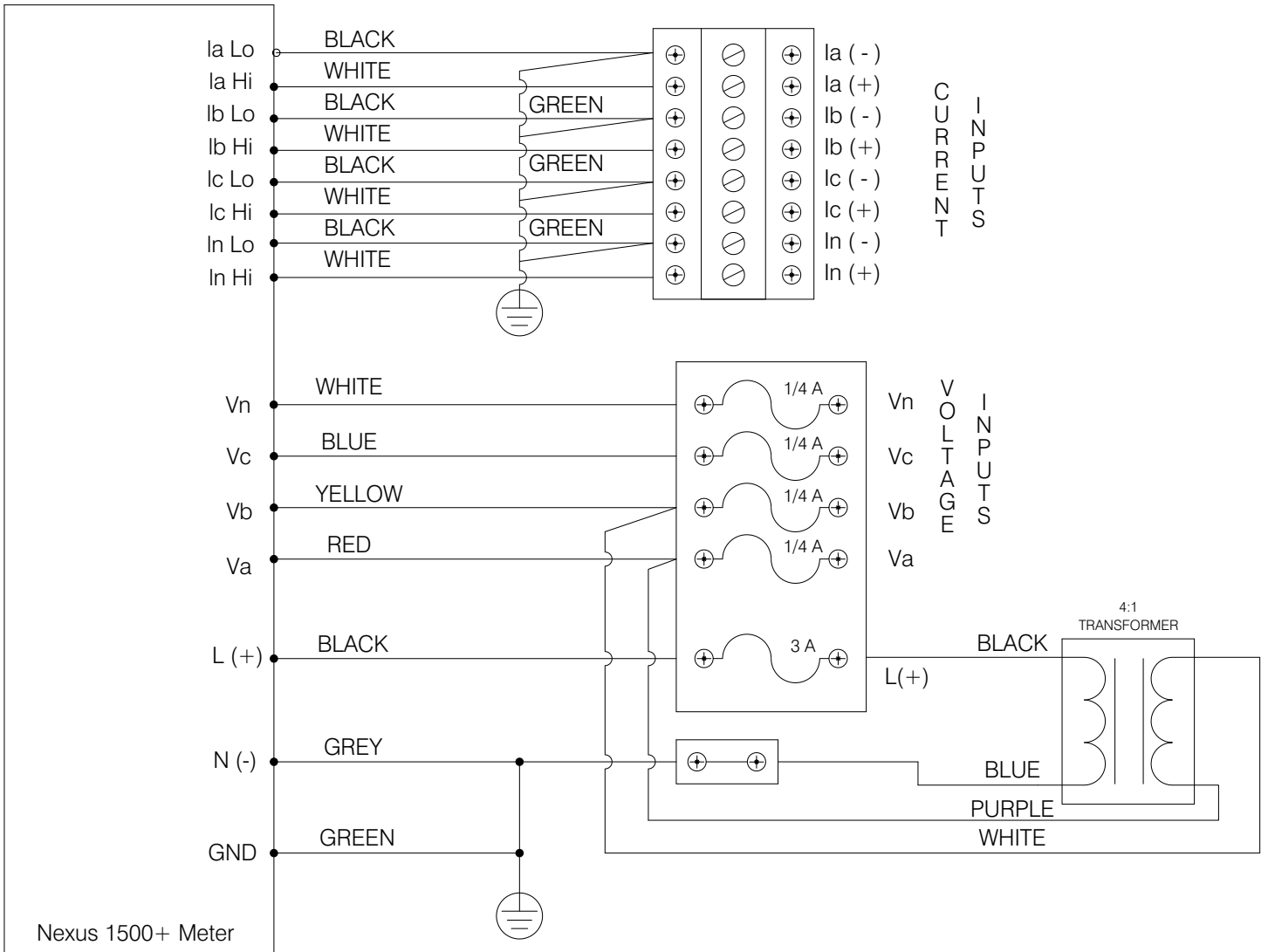

Figure 2.2: 277 Configuration Internal Wiring Schematic

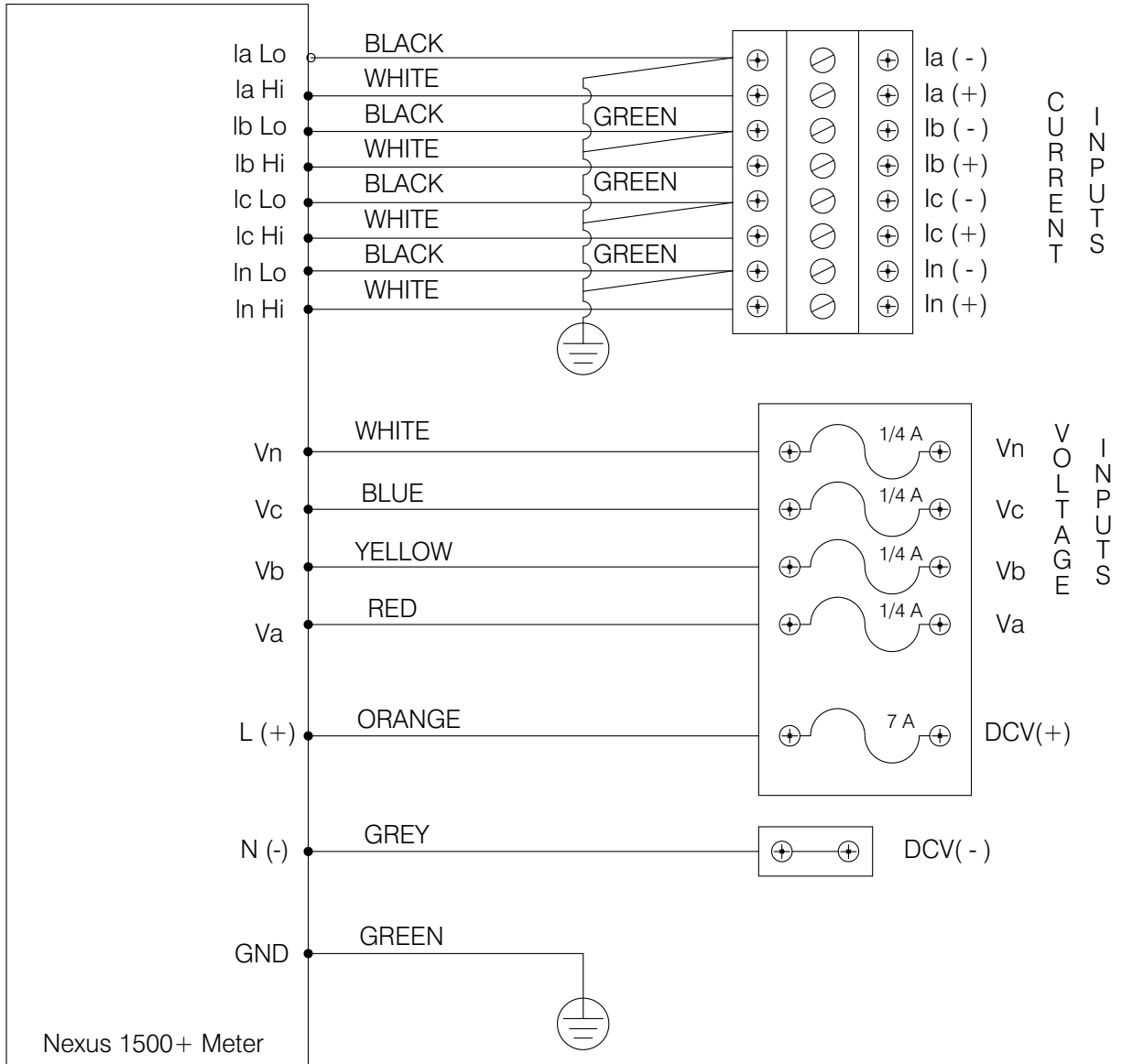

Figure 2.3: EXT24 Configuration Internal Wiring Schematic

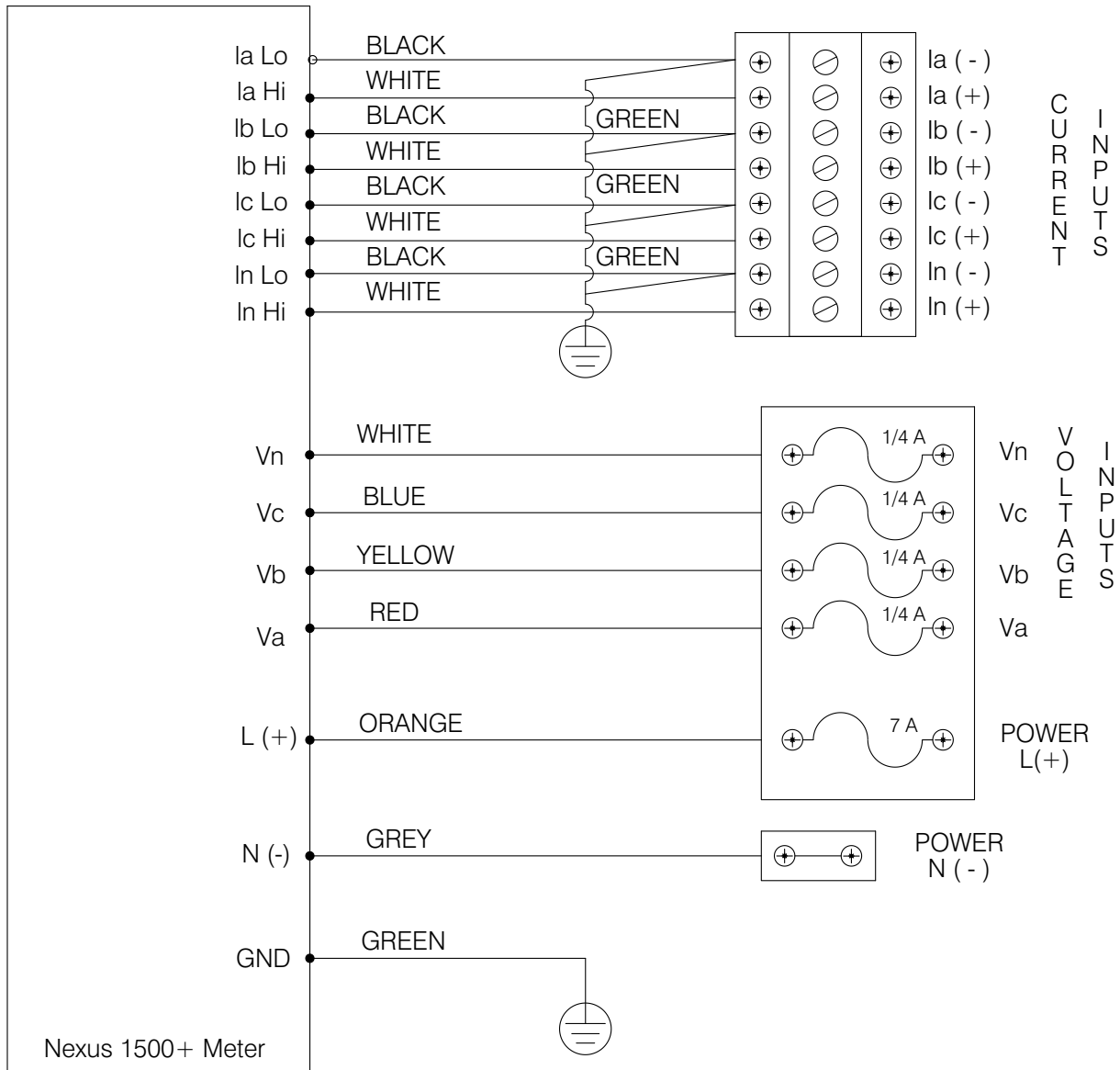

Figure 2.4: EXT120 Configuration Internal Wiring Schematic

2.1: Recommended Procedures for Wire Entry Hole Cutting

The enclosure does not come with wire entry holes (punch entries). They must be cut in the location you want depending on the installation. See Figure 2.4 for the locations that EIG recommends. See CAUTIONS on next page.

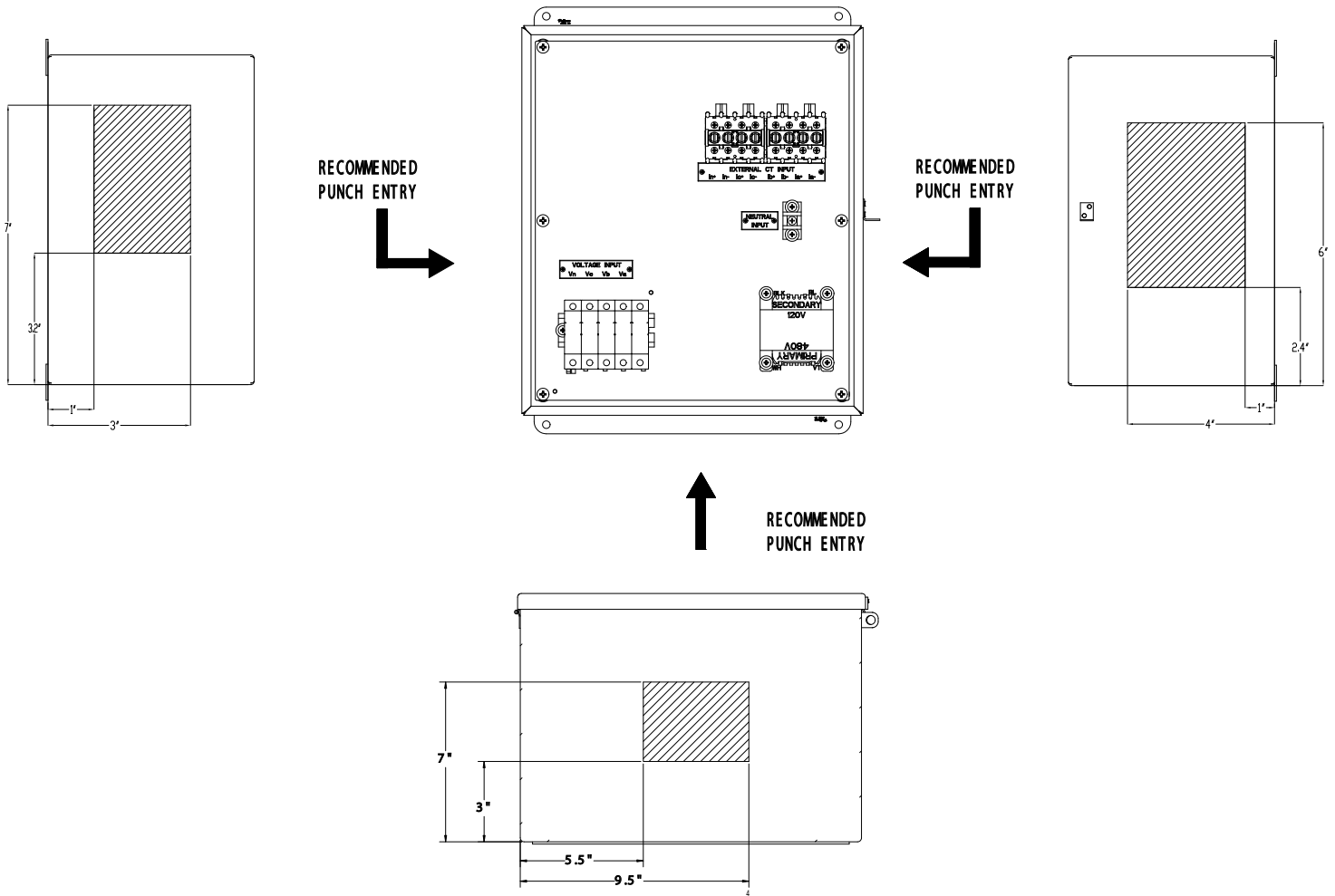

Figure 2.4: Recommended Locations for Wire Entry

CAUTIONS!

- There are numerous methods for making wire entry holes in the enclosure but it is imperative that no loose material generated during the process remains in the enclosure. During installation and cutting the wire holes, all equipment mounted inside or on the enclosure shall be protected from loose material.
- No matter what procedure is used the installer shall verify that the hole cutting process will not damage any of the wiring or components installed inside or on the enclosure.

The two recommended procedures for cutting the wire entry holes are as follows:

- Use a "C" frame punch to cut the wire entry holes. This type of punch does not require a pilot hole. A typical "C" frame punch is shown below.



Figure 2.5: "C" Frame Punch

- Regular punch:
 1. Place a magnet inside the enclosure where the pilot hole is to be cut and completely cover the area with masking tape (or other very sticky tape).
 2. Drill the pilot hole from the outside and do not let the drill pass more than $\frac{1}{4}$ " into the enclosure.
 3. Remove the tape, magnet, and cuttings and punch the hole.

After wiring and before energizing, vacuum the inside of the enclosure to make sure that it is free of foreign material. If a vacuum is not available use an alternate method to clean the inside of the enclosure. Do not use compressed air (or pressurized gas) to clean the inside of the enclosure as this may force cuttings into areas that cannot be seen, creating a hazardous condition.

IMPORTANT!

- All wire entry into the enclosure shall be accomplished with the use of recognized fittings or strain reliefs. Bare holes shall not be used.

2.2: Enclosure Installation

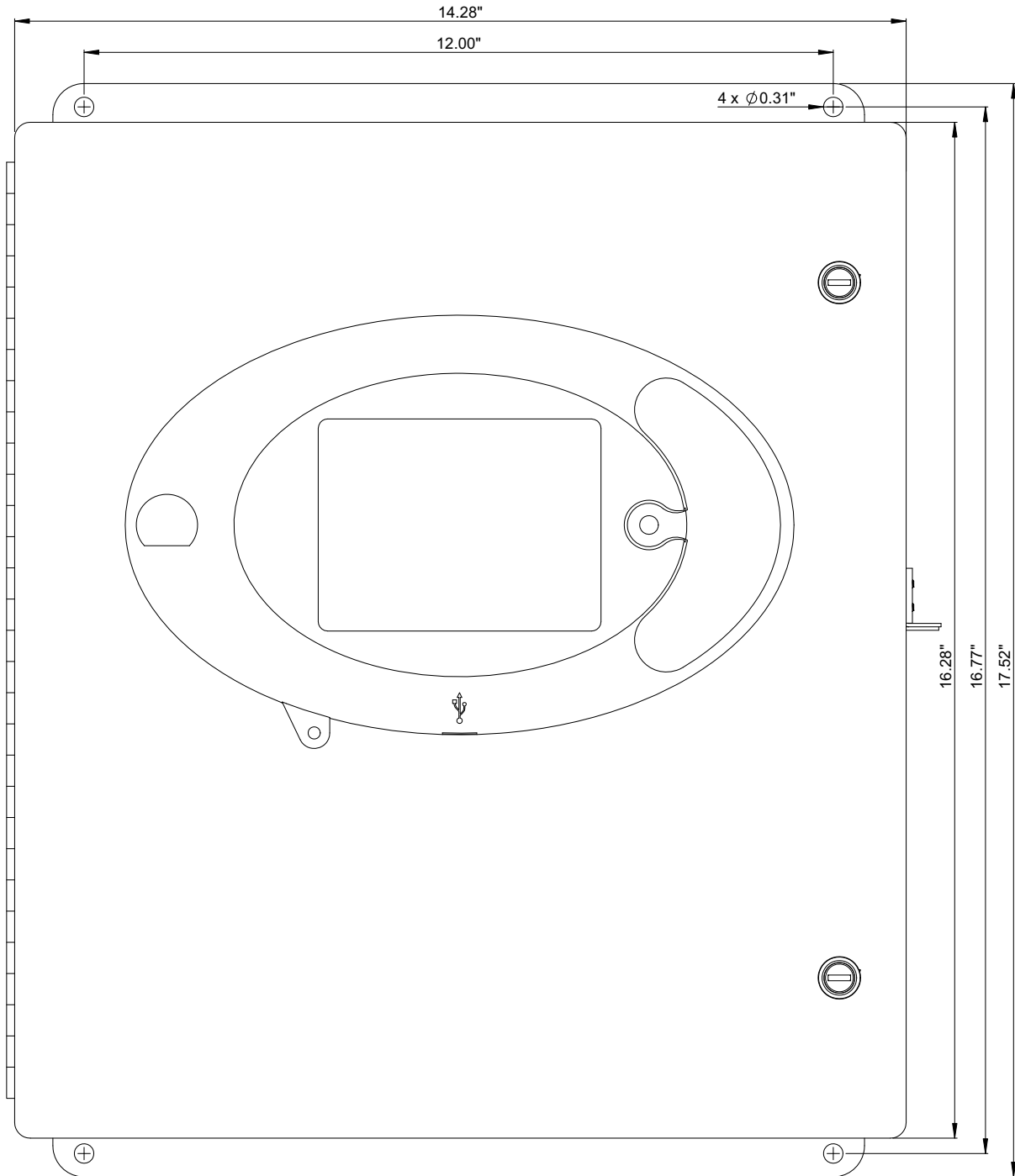

Figure 2.6: Enclosure Front Dimensions

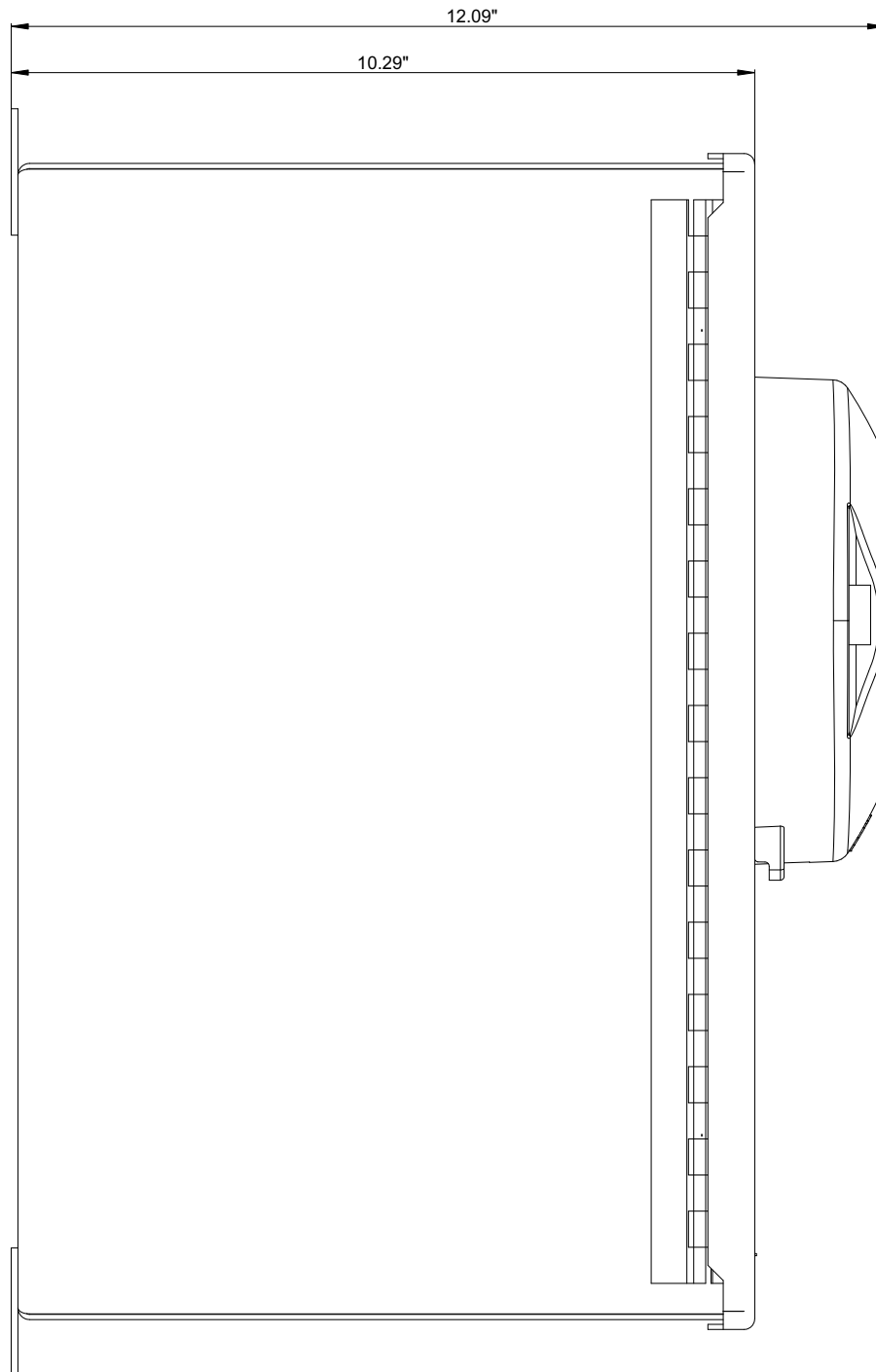

Figure 2.7: Enclosure Side Dimensions

2.2.1: Installation Steps

1. Install the 4 required mounting bolt anchors at locations as shown in Figure 2.6 (4 X 00.31”).

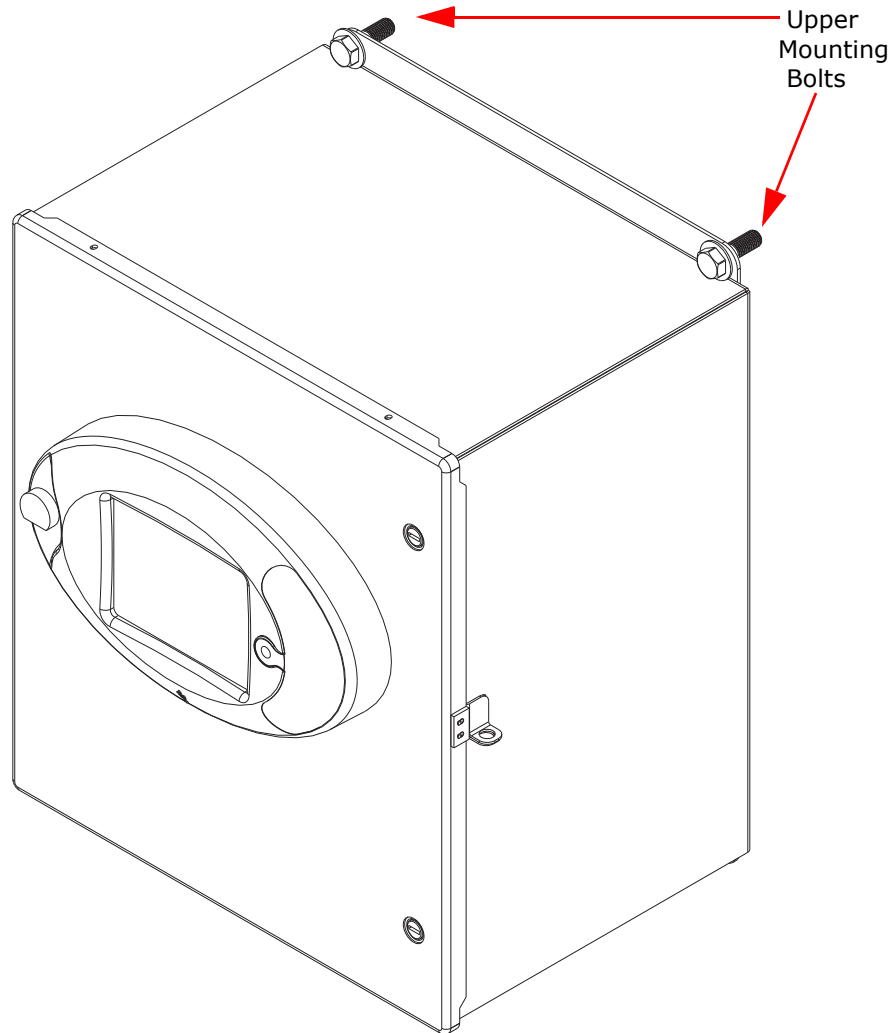

Figure 2.8: Mounting Bolt Installation, Upper Bolts

2. Gently lift the enclosure and guide the top mounting holes over the anchors. Install the top two bolts, but do not tighten them.
3. While still supporting the enclosure, install the two lower mounting bolts in the lower mounting flange, but do not completely tighten them. Use shims, if required, to prevent deformation of the enclosure when tightening the bolts, if the mounting surface is distorted.

4. Tighten all four mounting bolts after any required shimming is completed. See the figure below.

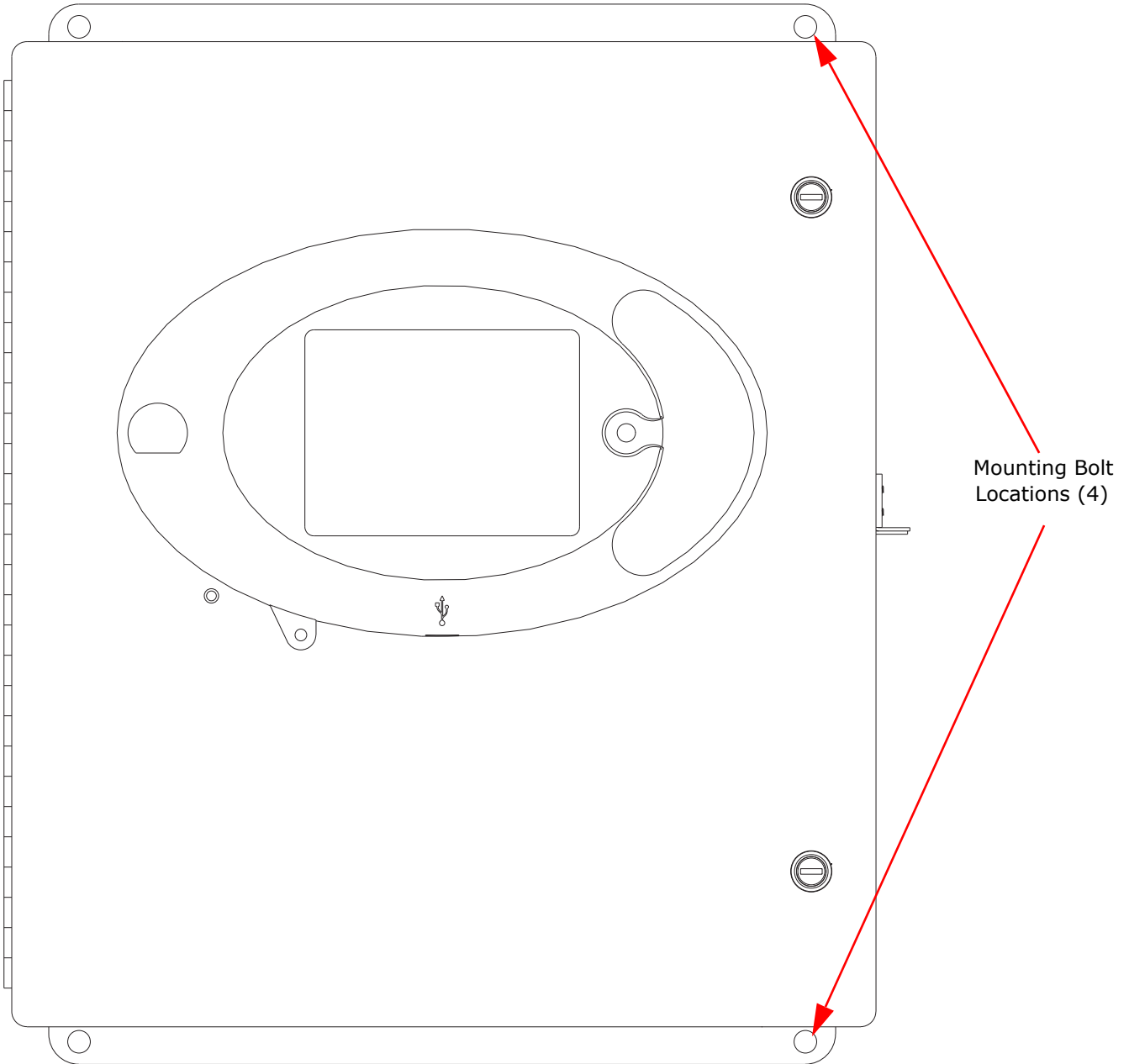

Figure 2.9: Mounting Bolt Locations

2.2.2: Door Locking Instructions

The enclosure has been fitted with means for securing the door so it cannot be opened or tampered with. The padlock bracket can be secured in place with a padlock (3/8 inch shackle diameter). See the figure below.

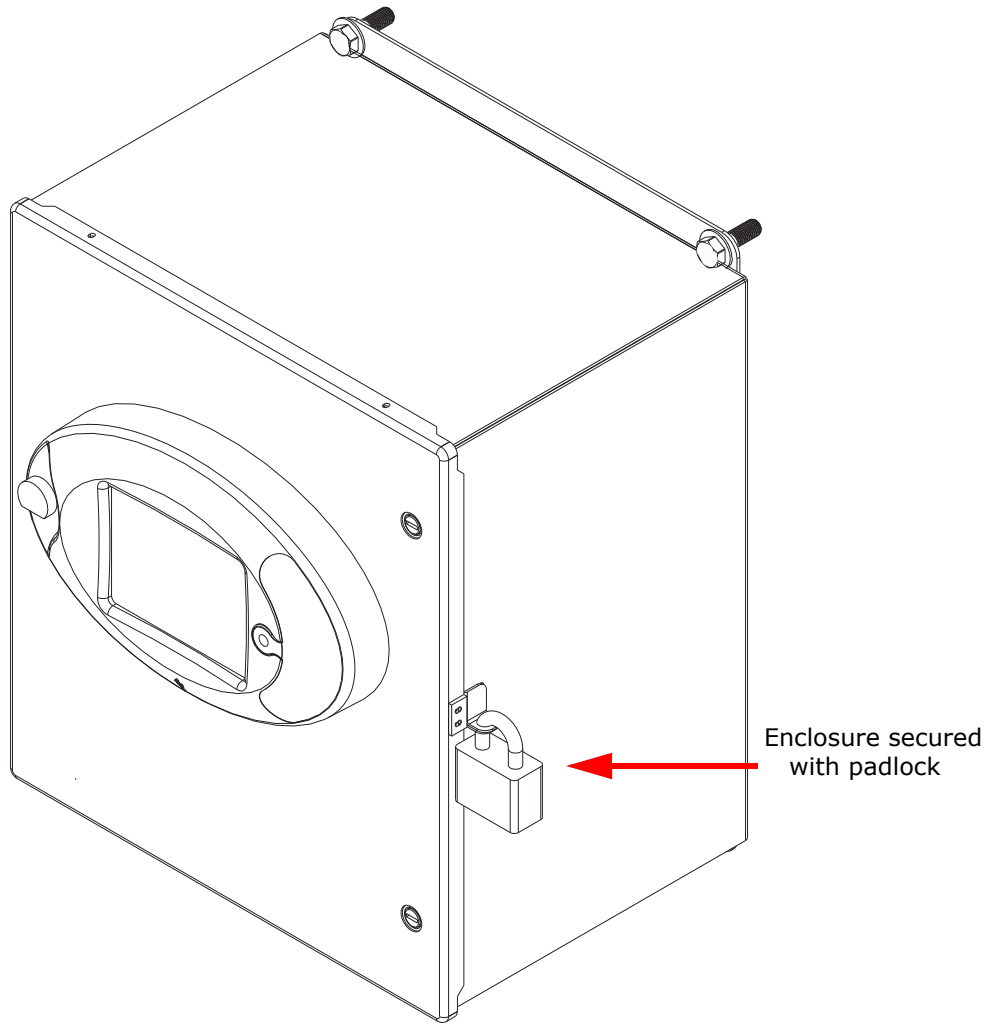

Figure 2.10: Door with Lock

3. Electrical Wiring

The Nexus® 1500+ Meter in Enclosure is factory wired and tested. Installation requires solidly mounting the enclosed unit and connecting field wiring. This document has diagrams of wiring options. Review and understand the appropriate diagrams for the unit you have ordered.

NOTE: See the diagram below for input wiring specifications. Consult your local and/or National Electric Code for external wiring requirements.

IMPORTANT! ALL CONNECTIONS TO THIS PRODUCT ARE TO BE WITH COPPER WIRE ONLY! TOUS LES CONNEXIONS À CE PRODUIT DOIVENT FAIRE UN FIL DE CUIVRE SEULEMENT!

All four enclosure models (120 - (120-240) V AC, 277 - 277/480 V AC, EXT24 - (18-60) V DC, and EXT120 - (120-240) V AC/DC) are pre-wired and programmed for either three phase or single phase operation.

NOTE: The current inputs are only to be connected to external current transformers provided by the installer. The CT's shall be Listed to ANSI/IEEE C57.13 and rated for the current of the meter used.

A DISCONNECTING MEANS AND UPSTREAM PROTECTION SHOULD BE INSTALLED FOR ALL CIRCUITS. A SHORT-CIRCUITING-TYPE TERMINAL BLOCK IS PROVIDED FOR THE CURRENT TRANSFORMER CIRCUIT.

INPUT WIRING SPECIFICATIONS*			
Location	Wire Size*	Screw Size	Maximum Torque
Shorting Block	#14 AWG Type THHN	#8-32 (Captive)	20 lbf-in (2.3 N-m)
Fuse Block L(+), V1-V3	#14 AWG Type THHN	Compression	20 lbf-in (2.3 N-m)
Fuse Block V4	#14 AWG Type THHN	Compression	20 lbf-in (2.3 N-m)
Earth Ground	#10-12 AWG Type THHN**	#8-32	10 lbf-in (1.2 N-m)

* **NOTE:** All wires shall be rated 90 °C/194 °F Minimum; use copper conductors only. Short circuit current rating is 10kA rms symmetrical.

**Or as required by the NEC or local codes.

3.1: Wiring Instructions



WARNING!

First connect Earth Ground as shown in the figure below.

AVERTISSEMENT! Branchez d'abord la mise à la terre comme indiqué dans le dessin ci-dessous.

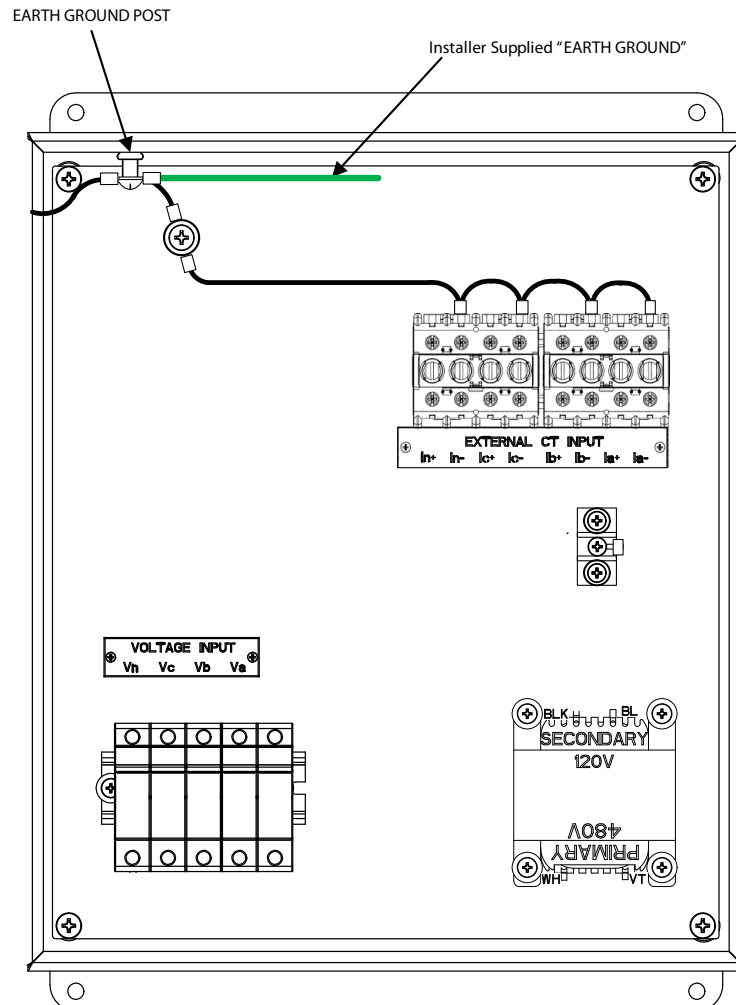

Figure 3.1: Earth Ground Connection

Understand the diagram(s) that pertain to your unit before you begin the field wiring. The following figures show the available wiring options. Understand your system and use the appropriate figures.



WARNING! CONTROL WIRING MAY HAVE VOLTAGE PRESENT THAT CAN CAUSE SEVERE PERSONAL INJURY OR DEATH. DE-ENERGIZE ALL CONDUCTORS BEFORE BEGINNING TO PERFORM ANY WIRING ACTIVITY TO OR WITHIN THE NEXUS® 1500+ METER IN ENCLOSURE.

AVERTISSEMENT! LE CÂBLAGE DES COMMANDES PEUT AVOIR UNE TENSION PRÉSENTE QUI PEUT PROVOQUER DES BLESSURES GRAVES POU LA MORT. METTRE HORS TENSION TOUS LES CONDUCTEURS AVANT DE COMMENCER LA RÉALISATION D'UNE ACTIVITÉ DE CÂBLAGE DANS L'ENCEINTE DE L'ASSEMBLAGE NEXUS® 1500+.

3.1.1: Wiring Diagrams

The wiring diagrams for the Nexus® 1500+ in Enclosure begin on the next page.

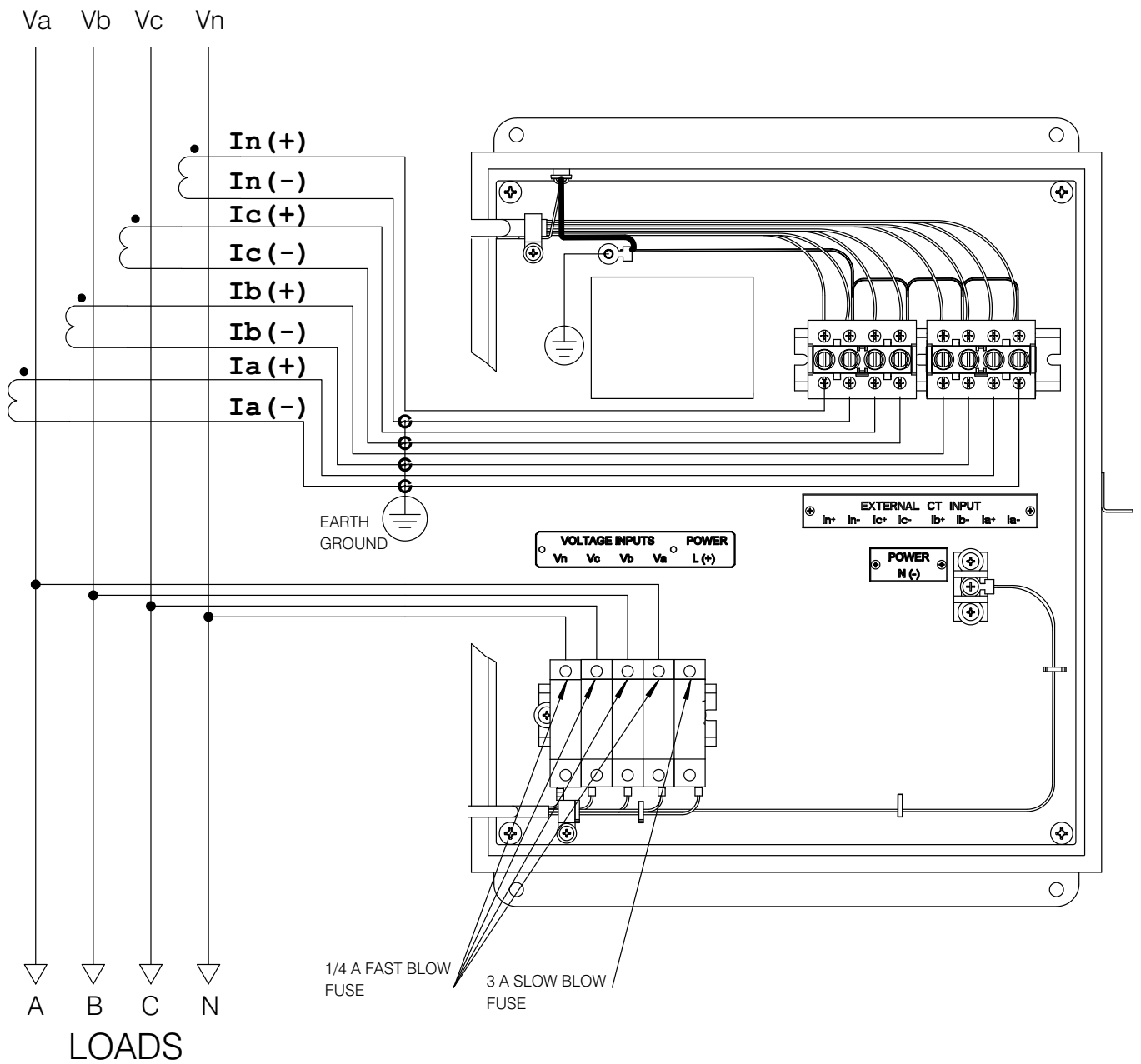

Figure 3.2: 4 Wire WYE Direct Hookup, 3 Element

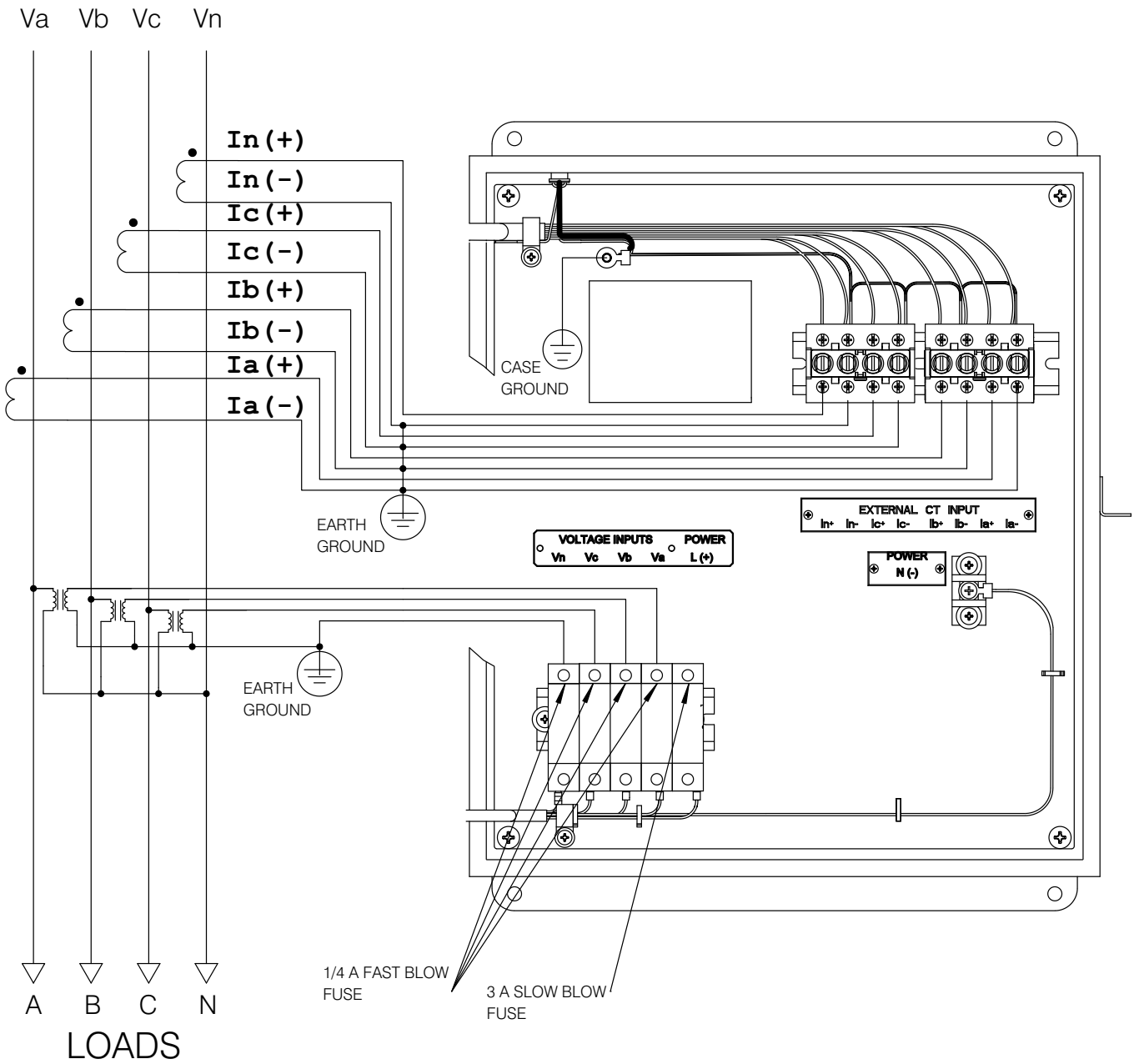

Figure 3.3: 4 Wire WYE 3 PT Hookup, 3 Element

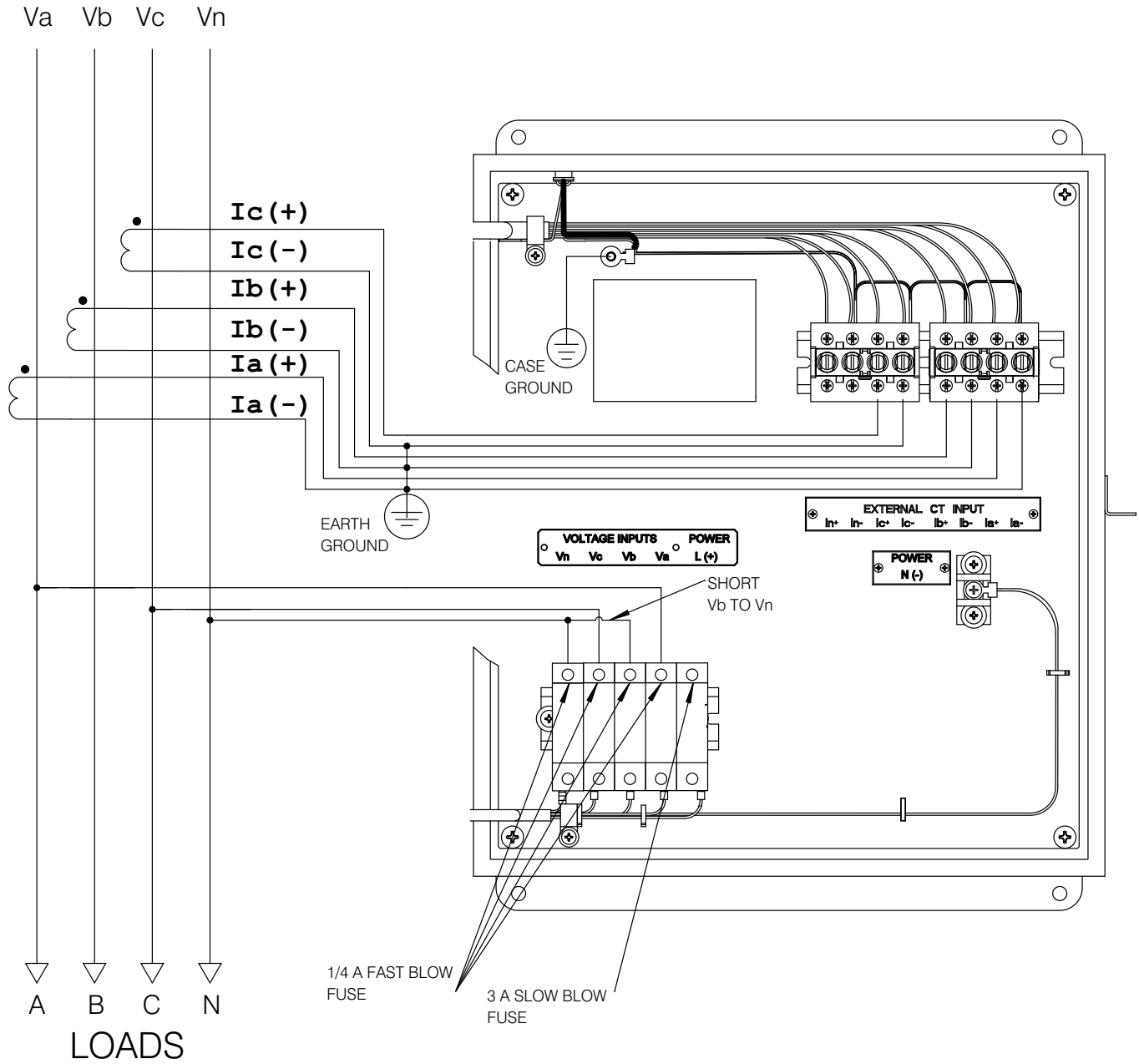

Figure 3.4: 4 Wire WYE Direct Hookup, 2.5 Element

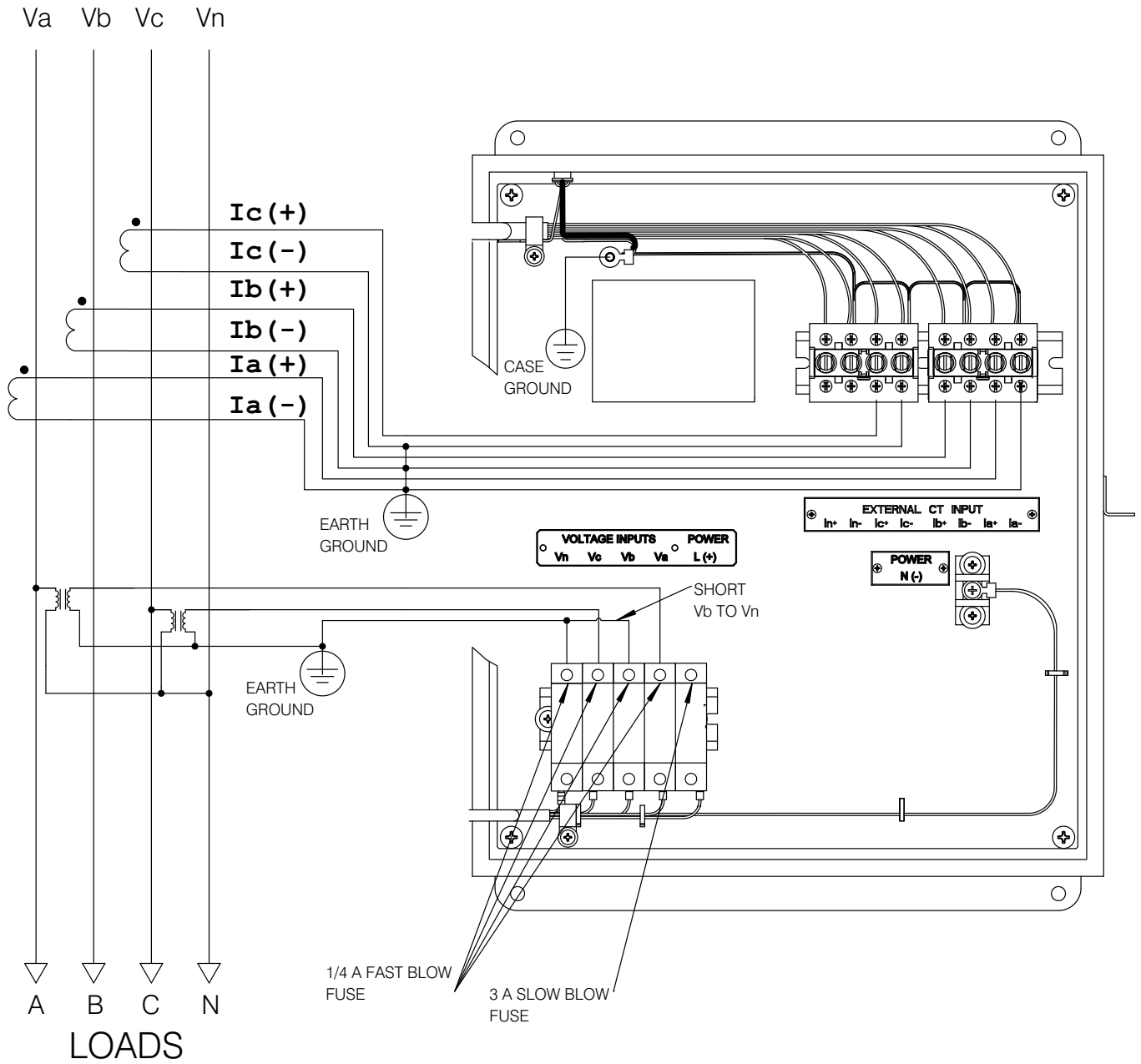

Figure 3.5: 4 Wire WYE 2 PT Hookup 2.5 Element

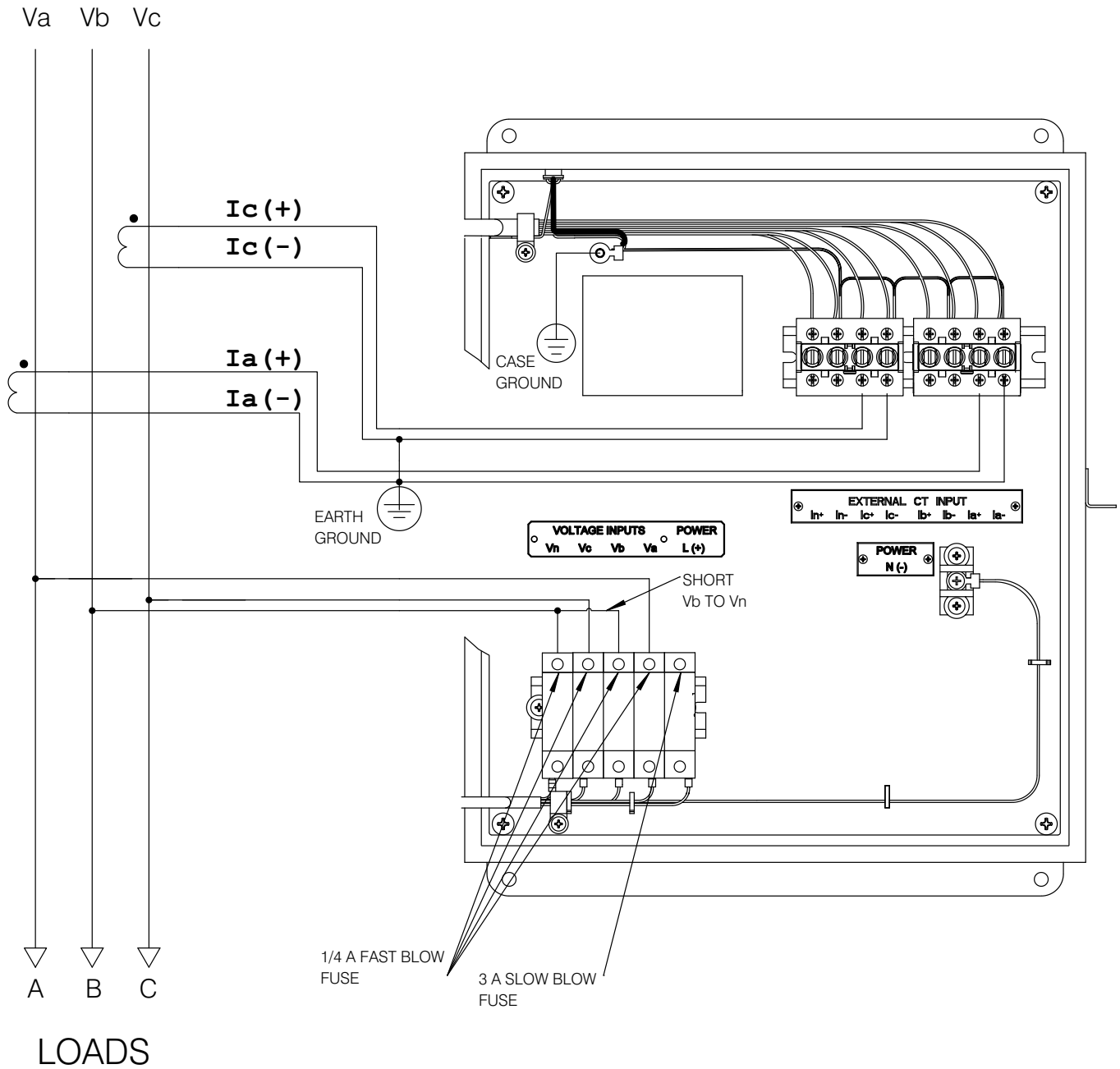

Figure 3.6: 3 Wire Delta Direct Hookup, 2 Element

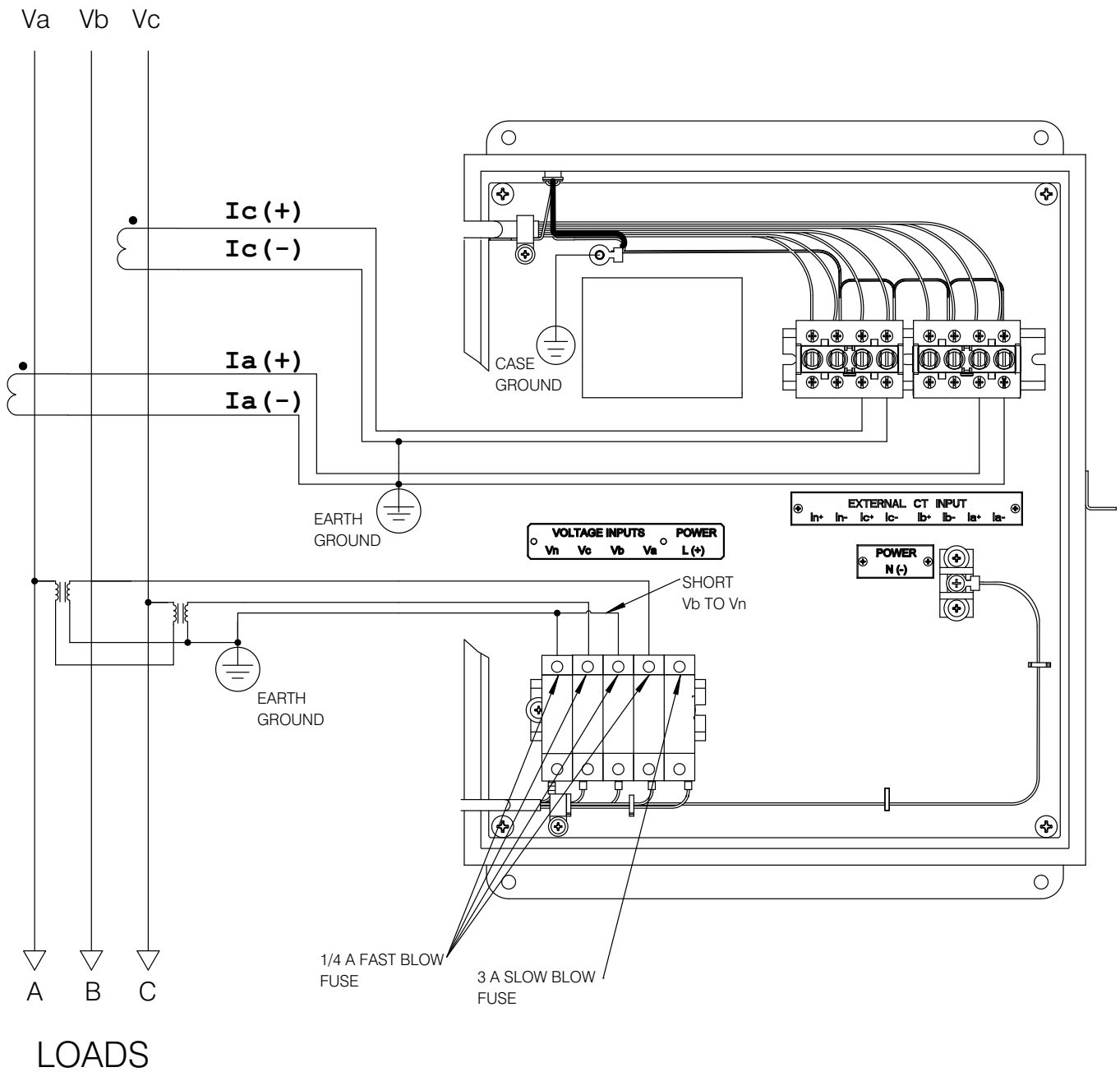

Figure 3.7: 3 Wire Delta 2 PT Hookup, 2 Element

This page intentionally left blank.

4: Operation

4.1: Overview

The Nexus® 1500+ Meter in Enclosure is equipped with three 10 mm x 38 mm, 600 V 1/4 A fast acting fuses and two 10 mm x 38 mm, 500 V, 3 A (for the 277 V and 120 V configurations) or 7 A (for the 24 V DC configuration) Time Delay fuses for the protection of the meter's sense voltage and control power circuits, respectively.

A disconnecting means and upstream protection should be installed for all voltage circuits. Short-circuiting type terminal blocks are provided for the current transformer circuit and are equipped with captive shorting screws (see instructions in Section 5.1).

The temperature rating for enclosure operation is (0 to +50) °C/(32 to 122) °F.

Refer to the *Nexus® 1500+ Meter System User Manual* for specific operating instructions for the meter in your enclosure. You can download the manual from EIG's website:

<https://www.electroind.com/products/nexus-1500-power-quality-meter-in-enclosure/>

4.2: Troubleshooting

Symptom: Extremely inaccurate readings of voltage and/or harmonics.

Perform these two tests:

1. With fuses removed from the unit, test the fuses with an ohmmeter. All of the fuses must show a resistance of <2 Ohms.
2. With the unit fully powered, measure the voltage on the input side and output side of the fuse. The voltages should differ by less than 1 Volt.

This page intentionally left blank.

5. Maintenance

The Nexus® 1500+ Meter in Enclosure is designed to be relatively maintenance-free under normal use. However, because of the variability of application conditions and the importance placed on dependable operation and inspection, you should perform maintenance checks on a regularly scheduled basis. Visually inspect for loose parts, wires, and/or hardware; inspect for discoloration of insulation and damaged or discolored components; be alert for accumulation of dirt and/or moisture on structure; check operation of disconnecting means and continuity of fuses, where applicable.

5.1: Removing a Meter From Service

Follow these steps:

1. De-energize all circuits feeding the case.
2. If possible de-energize lines that the CTs are on.
3. Tighten all the shorting screws on all the CT shorting blocks by turning all the screws clockwise until they bottom out.



WARNING! If the meter must be removed from service, the secondary side of the current transformers **MUST** be short circuited to prevent a dangerous high voltage condition from appearing across the secondary wires of the current transformer. **Arcing and damage to personnel and/or equipment can occur if the screws provided on the shorting block are not installed in the correct locations, prior to disconnecting any wires.**

AVERTISSEMENT! Si le compteur doit être enlevé du service, le côté secondaire du transformateur actuel DOIT être court-circuité pour prévenir une condition de haute tension dangereuse d'apparaître dans les câblages secondaires du transformateur actuel. La brûlure d'arc et l'endommagement d'un équipement ou des blessures sont susceptibles de se produire si les vis fournies sur le court-circuit ne sont pas installées dans les emplacements corrects avant de débrancher les câbles.

The four screws on each of the two shorting blocks are used to short the high (+) sides and the low (-) sides to an internal buss bar. The pre-installed jumper connects all lows together and to ground.



WARNING! The screws need to be screwed down until the screw makes contact with the internal bar, enabling the bar to become electrically common with the terminal strip, and grounded.

Les vis doivent être vissées jusqu'à ce que la vis soit en contact avec la barre interne, permettant à la barre de devenir électriquement commune à la barrette de raccordement et mise à la terre.

The figure below shows where the screws are located that must be tightened down to short the CTs.

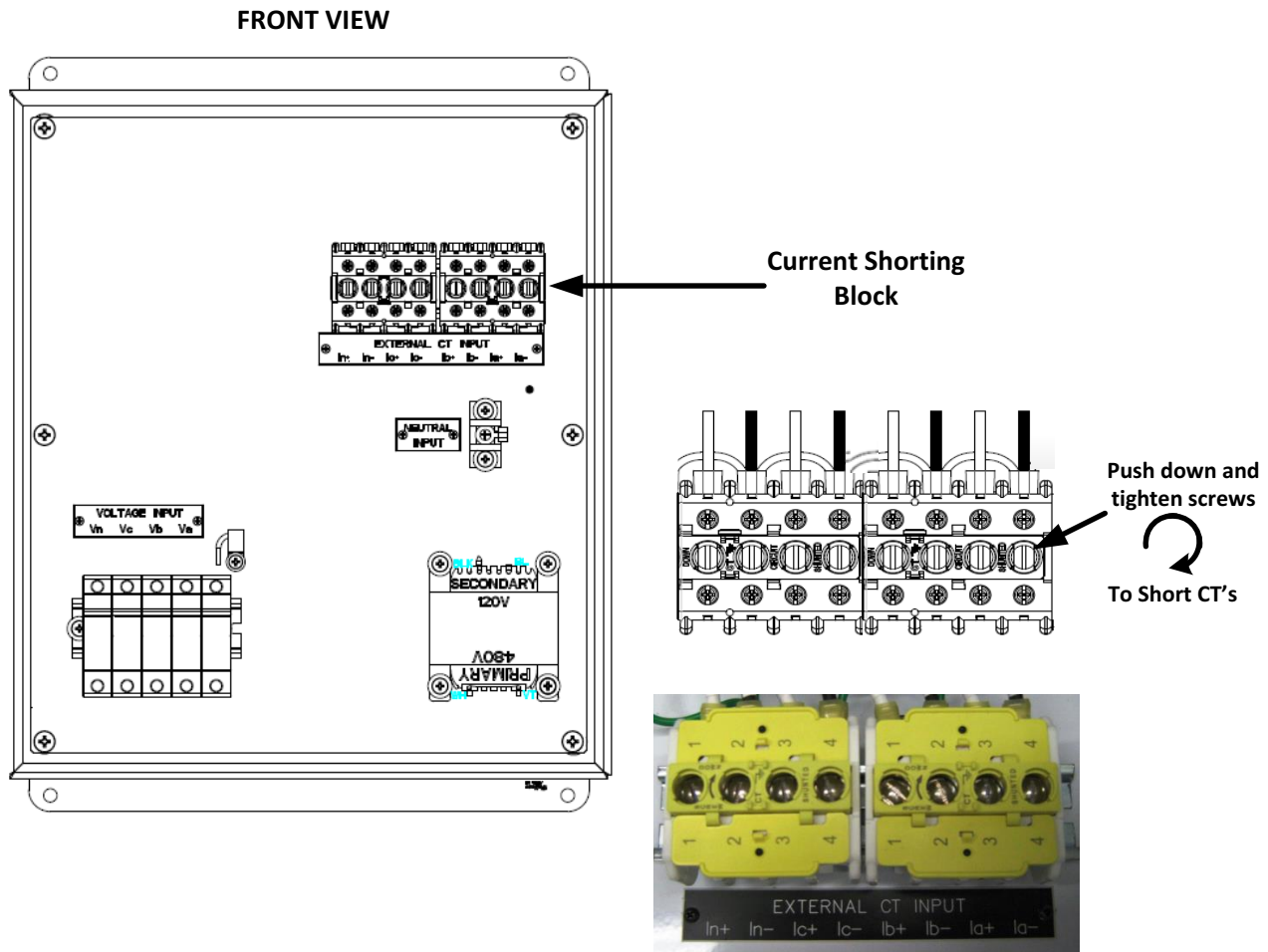

Screws shown in "Shorted" position

Figure 5.1: Shorting Block Location



WARNING! When you re-install the meter, make sure all CT connections are made **BEFORE** unscrewing the shorting screws. See Section 5.2.

AVERTISSEMENT! Lorsque vous réinstallez le compteur, assurez-vous que toutes les connexions de TC (transformateur de courant) sont faites **AVANT** de dévisser les vis de court-circuit. Voir la section 5.2.

4. Open the 5 section fuse holder, disconnecting the voltage circuit.
5. Unscrew and disconnect all the current leads to the meter.
6. Disconnect all connectors to the meter.
7. Remove the 4 DIN mounting brackets.
8. Remove the meter.

5.2: Reinstalling the Meter

Follow this procedure to reinstall the meter:

1. Place meter in cover cutout.
2. Attach the 4 DIN mounting brackets and tighten their screws.
3. Insert all connectors into the appropriate sockets on the back of the meter.
4. Connect all the current leads to the meter making sure they are attached in the proper order.
5. Close the 5 section fuse holder, reconnecting power to the meter.
6. Unscrew fully the 8 shorting screws on the CT block until they are in the position shown in the figure below.



Loosen



To unshort CT's

Be sure shorting screws are fully unscrewed and appear as shown

Figure 5.2: Shorting Screws Returned to Their Storage Positions

7. Verify that no foreign material remains inside the enclosure - if there is any, clean it out.
8. Energize all circuits and verify operation.

6. Ordering Information

ENCNX1500+ - **277** - **D2** - **60** - **20** - **V2** - **X** - **NTEO** - **6RO1** - **X**
 1 2 3 4 5 6 7 8 9 10

1. Model:

ENCNX1500+ - Nexus® 1500+ Meter in NEMA 1 Enclosure

2. Power System:

120 - (100-240) V AC Line Powered

277 - 277/480 V AC, with supplied control power transformer Line Powered

EXT24 - (18-60) V DC* External Powered

EXT120 - (120-240) V AC/DC External Powered

3. Power Supply:

115AC - (100-240) V AC @50/60 Hz

D2 - Universal (100-240) V AC @50/60 Hz or (100-240) V DC

D - (18-60) V DC*

4. Frequency:

50 - 50 Hz

60 - 60 Hz

5. Current Class:

20 - 20 A

2 - 2 A

6. Virtual Switch:

V1 - Standard meter with 512 MB memory; 512 samples/cycle

V2 - V1 plus 1 GB memory; 1024 samples/cycle; IEC 61850

V3 - V2 plus 4 GB memory; 50 MHz Transient Recording

V4 - V1 + Synchrophasor PMU and Resilient Cyber Security

V5 - V2 + Synchrophasor PMU and Resilient Cyber Security

V6 - V3 + Synchrophasor PMU and Resilient Cyber Security

7. Communication Expansion/Slot 1:

X - No option

485P - 2 RS485 ports and 4 pulse outputs

8. I/O Slot 1:

X - No option

NTRJ - Second Ethernet card

NTFO - Second fiber optic network card (ST terminated)

9. I/O Slot 2:

X - No option

6RO1 - 6 relay outputs

16DI1 - 16 status inputs

10. I/O Slot 3:

X - No option

6RO1 - 6 relay outputs

16DI1 - 16 status inputs

* These two options must be ordered together.

Example on previous page:

ENCNX1500+ - 277 - D2 - 60- 20- V2- X- NTFO - 6RO1 - X

(Nexus® 1500+ Meter in Enclosure, with 277 Power System, Universal (100-240) V AC @50/60 Hz or (100-240) V DC power supply, with 60Hz frequency, Current Class 20, V2 virtual switch, no expansion communication port, a fiber optic I/O card, and a relay output I/O card.